

Notes: (Unless Otherwise Specified).

- 1) ALL DIMENSIONS ARE IN MM.
- 2) SOLDER BALL ALLOY: SEE PART NUMBER TABLE.
- 3) BALL DIAMETER (BEFORE REFLOW): 0.40mm.
- 4) SOLDER MASK DEFINED PAD OPENING: 0.33mm [13 MIL].
- 5) PAD Cu DIAMETER: 0.508mm [20 MIL].
- 6) SUBSTRATE MATERIAL: BT (ALTERNATE FR4).
- 7) DUMMY DIE IS OPTIONAL.
- 8) DAISY CHAIN PATTERN (SEE PAGE 2).
- 9) MSL-3 RECOMMENDED BAKING 24 HOURS @ 125 °C TO REMOVE MOISTURE PRIOR TO SOLDERING TO PC BOARD.

PART NUMBER TABLE				
PART NUMBER	BALL ALLOY	BALL CODE	RoHS	Si DIE
SBGA676T.8C-DC269D	Sn96.5/Ag3.0/Cu0.5	SAC305	YES	YES
SBGA676T.8-DC269D	Sn63/Pb37	Sn63	NO	YES

APPROVALS		DATE				
DRAWN	T. Au	07/11/2017				
ENG	M. Hart	07/11/2017	TITLE		SBGA676T.8-DC269D DAISY CHAIN DUMMY	
MFG			SCALE	SIZE	DRAWING NO.	REV
QA			3.5:1	A	582695	A
CUST			DO NOT SCALE DRAWING			SHEET 1 OF 4
REVISED						

### BALL VIEW

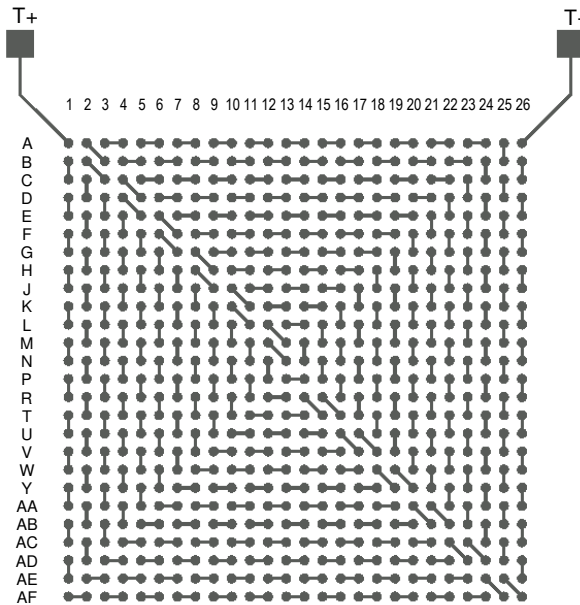
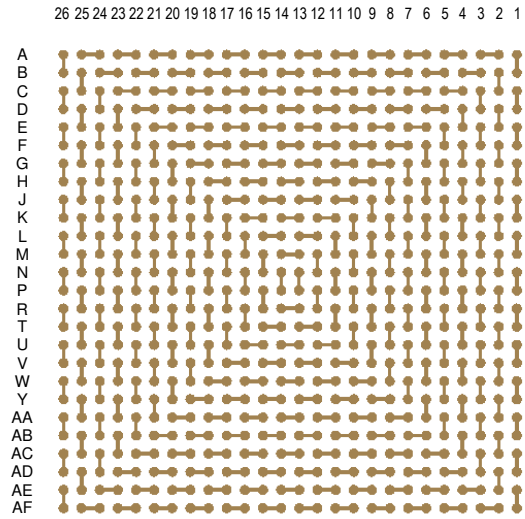

TEST VEHICLE BOARD

### BOTTOM SIDE (TOP X-RAY VIEW)

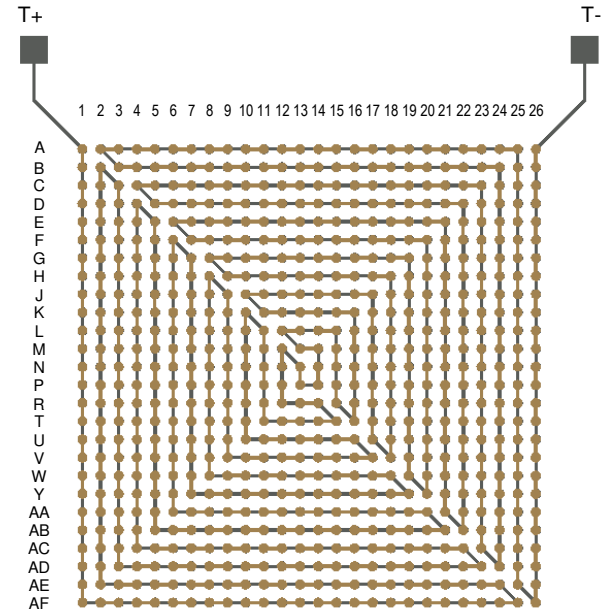
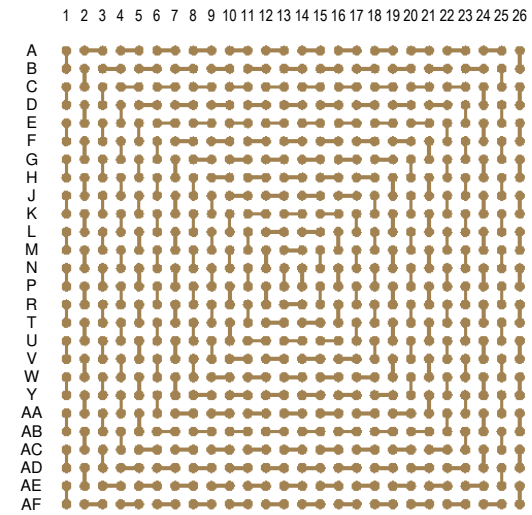

AFTER MOUNTING

**Notes:**

- 1) PCB BOARD DIMENSIONS ARE PRESENTED ONLY AS A GUIDELINE. DESIGNERS SHOULD USE THEIR OWN EXPERIENCE WHEN DESIGNING PCB.
- 2) PCB Cu BALL PAD DIAMETER 0.508mm [20 MIL].
- 3) PCB DAISY CHAIN TRACING LINE WIDTH 0.152mm [6 MIL].
- 4) SMD (SOLDER MASK DEFINED) PAD OPENING 0.33mm [13 MIL].



TITLE			
SBGA676T.8-DC269D DAISY CHAIN DUMMY			
SCALE	SIZE	DRAWING NO.	REV
	A	582695	A
DO NOT SCALE DRAWING			SHEET 2 OF 4

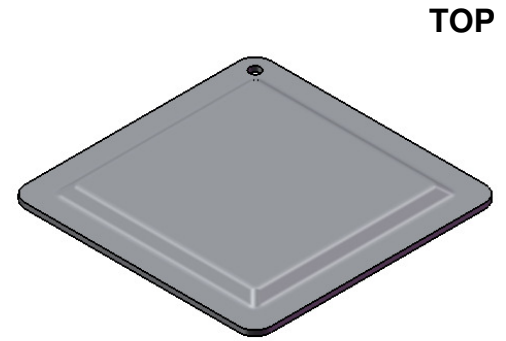
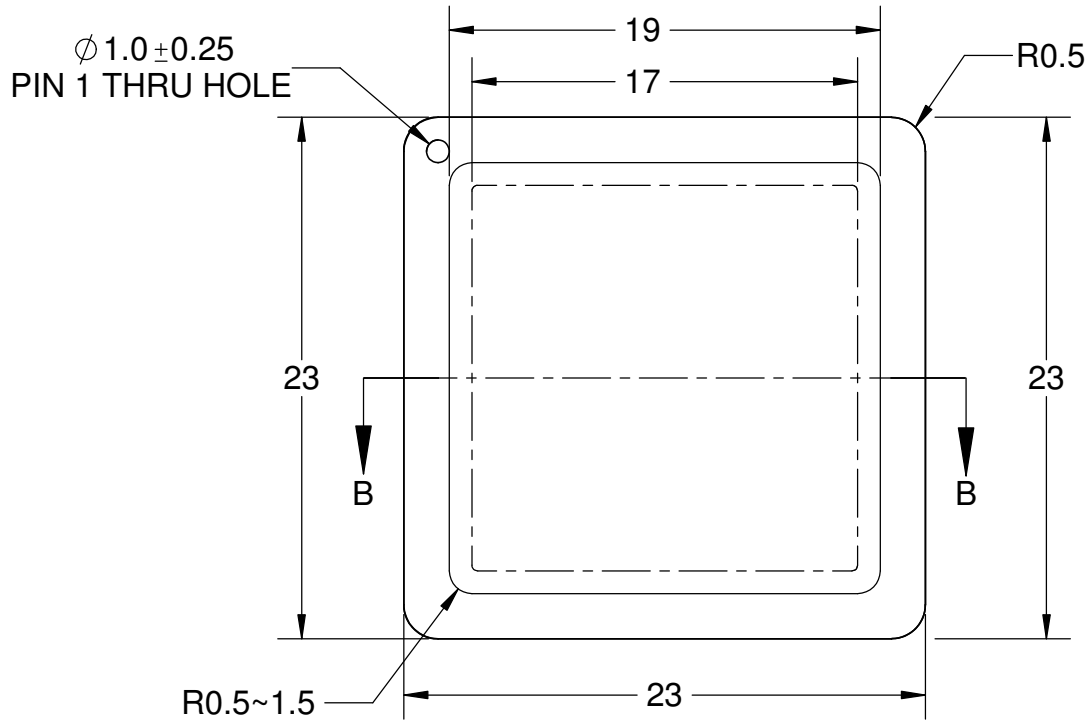

MODEL

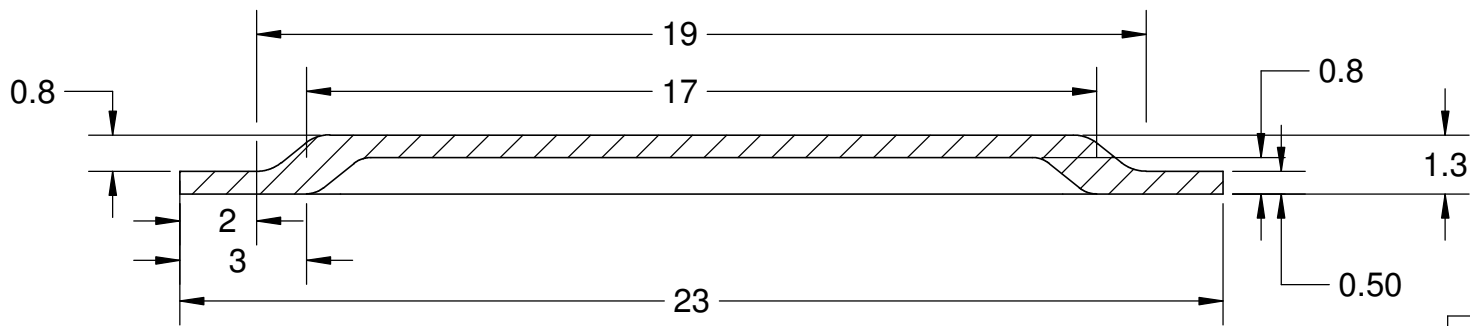

SECTION B-B  
SCALE 6 : 1

**TopLine**<sup>®</sup>

TITLE SBGA676T.8-DC269D  
DAISY CHAIN DUMMY

SCALE	SIZE	DRAWING NO.	REV
	A	582695	A

DO NOT SCALE DRAWING

SHEET 3 OF 4

**MODEL**

**TOP**

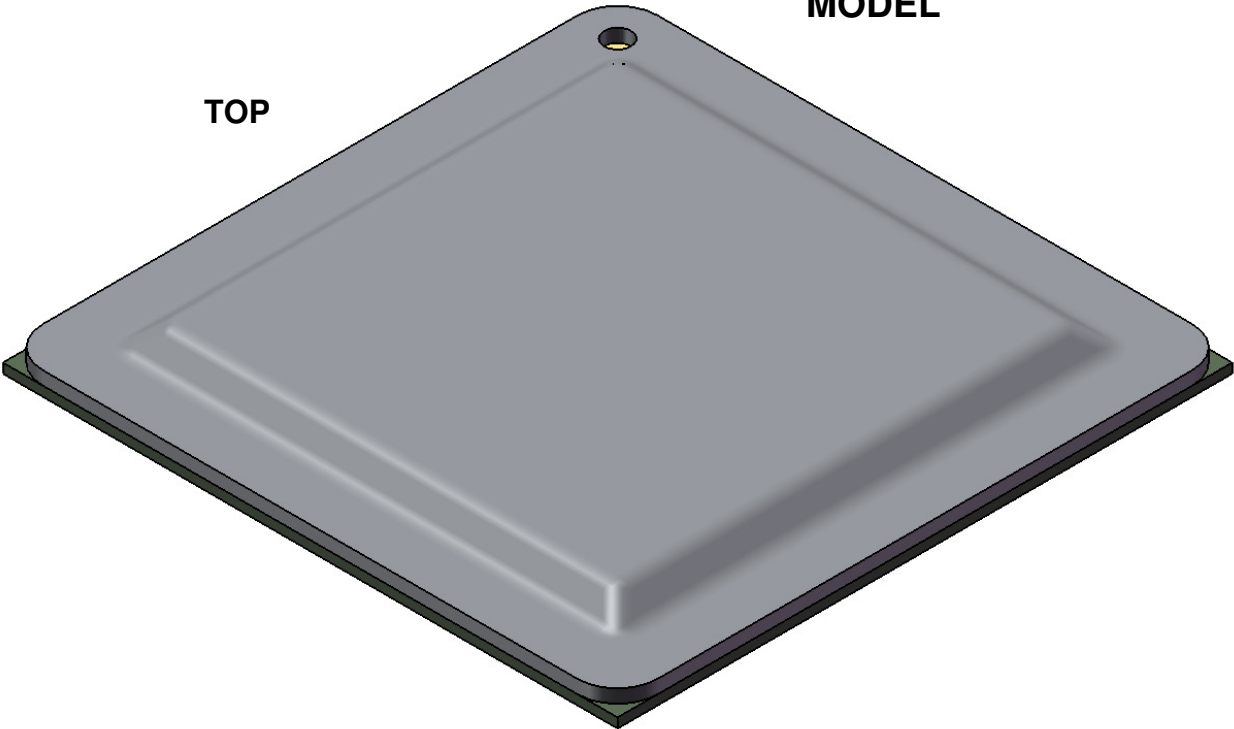

**BALL VIEW**

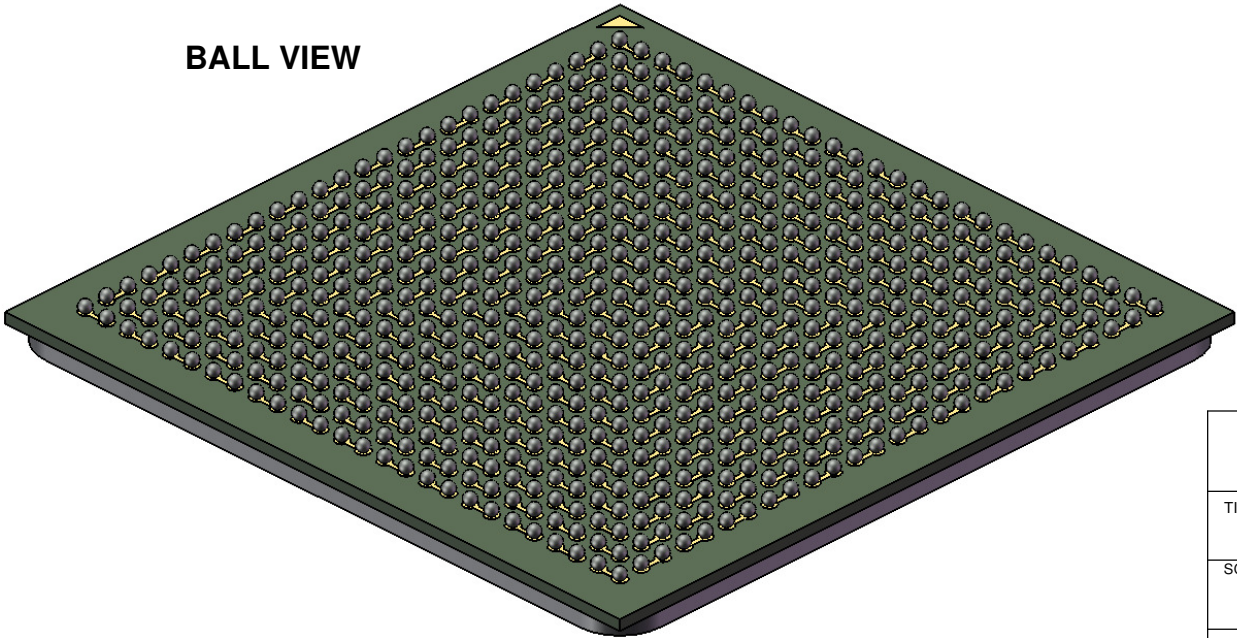

<b>TopLine<sup>®</sup></b>			
TITLE		SBGA676T.8-DC269D DAISY CHAIN DUMMY	
SCALE	SIZE	DRAWING NO.	REV
	A	582695	A
DO NOT SCALE DRAWING			SHEET 4 OF 4